

QG series

QG40N-series

QG40N-KAXYZ-16,0-AI-PT

Acceleration sensor

3 axis

Factory programmable device

Output: 4 - 20 mA

Measuring range factory programmable

between 0,1 g and 16 g

Measuring range

Factory defaults: ± 16 g



General specifications 12324, v20230725

Plastic injection molded housing (Arnite T06 202 PBT black)

40x40x25 mm

Included: 2x M3x25 mm zinc plated steel pozidrive pan head screws, self-tapping (PZ DIN 7500CZ)
Mounting on flat surface only. Screw with care

IP67

0 - 95% (non condensing, housing fully potted)

approx. 45 gram (cable excluded)

10 - 30 V dc

Yes

≤ 15 mA (excluding output signal)

-40 .. +80 °C

-40 .. +80 °C

Factory defaults: ± 16 g

Yes (12 mA = 0 G), range: $\pm 5^\circ$ (horizontal axes only)

0 - 50 Hz

overall 0,5 g typ.

± 30 mg typ. (± 60 mg 2σ) after zero adjustment

$\pm 0,04$ g typ.

$\pm 2\%$ typ.

10 mg

± 1 mg/K typ.

10.000g

4 - 20 mA

Rload $\leq (50 \cdot V_s - 300)$ (Ω) (Eg: $V_s = 24$ V: Rload $\leq 900 \Omega$)

Yes ($T < 55^\circ\text{C}$), Max 10 s ($T > 55^\circ\text{C}$)

3 ms

Factory programmable only

Housing

Dimensions (indicative)

Mounting

Ingress Protection (IEC 60529)

Relative humidity

Weight

Supply voltage

Polarity protection

Current consumption

Operating temperature

Storage temperature

Measuring range

Centering function

Frequency response (-3dB)

Accuracy (overall @20°C)

Offset error

Non linearity

Sensitivity error

Resolution

Temperature coefficient

Max mechanical shock

Output

Output load

Short circuit protection

Output refresh rate

Programming options

QG40N-KXYZ-16,0-AI-PT

$I_{out} = 12 + g/2$ [mA]
clipping outside measuring range

Zeroing: eliminate mech. offsets
Connect zeroing input to ground (>0,5sec) within 1 min. after power up. Normally the zeroing input should be left unconnected.

Transfer characteristic

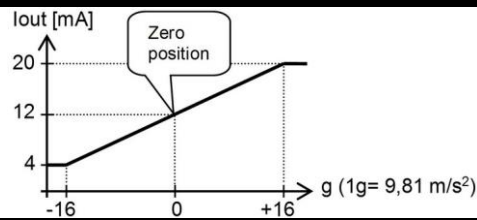

The default 0 g position is when the sensor is mounted horizontal or vertical and no acceleration is applied. The axis parallel to earth gravity will indicate 1 g, the two horizontal axes will indicate 0 g.

Connect output-X and/or output-Y and/or output-Z according to the plot at the right

Mounting in all horizontal or vertical positions possible

The two horizontal axes can be zero-ed within $\pm 5^\circ$ tilt to eliminate mounting offsets.
The axis parallel to earth gravity cannot be zero-ed.

Measurement orientation

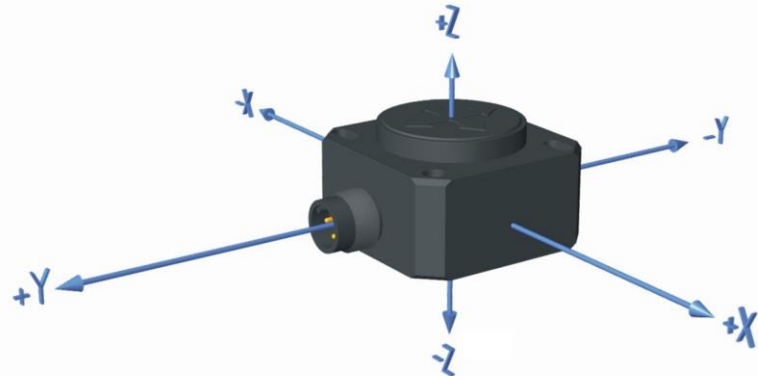

Connectivity (cable length $\pm 10\%$)

2 m PUR/TPE Li12y11y, black \varnothing 5,2 mm, wires: 6x0,34 mm² DIN colors

Connection

Wire / pin coding

White	Zeroing
Brown	+ Supply Voltage
Green	GND
Yellow	Output X
Grey	Output Y
Pink	Output Z

Mechanical dimensions (indicative only)

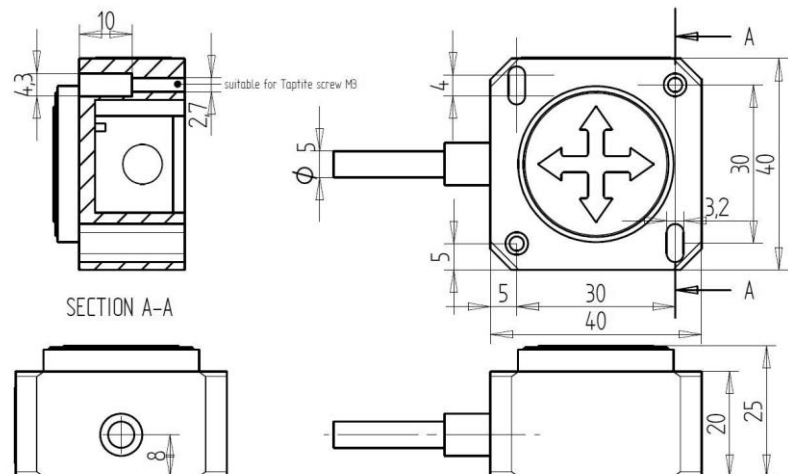

Intended use, Remarks

QG series sensors are intended to measure inclination/acceleration/tilt. Flawless function (acc. spec.) is ensured only when used within specifications. This device is not a safety component acc. to EU Machine Directive (ISO13849). For full redundancy two devices can be used. Modifications or non-approved use will result in loss of warranty and void any claims against the manufacturer.

As this device is accelerometer-based the sensor is inherent sensitive for accelerations/vibrations. Application specific testing must be carried out to check whether this sensor will fulfil your requirements.